

LatticeMico GPIO

The LatticeMico GPIO is a general-purpose input/output core that provides a memory-mapped interface between a WISHBONE slave port and general-purpose I/O ports. The I/O ports can connect to either on-chip or off-chip logic.

Version

This document describes the 3.4 version of the LatticeMico GPIO.

Features

The LatticeMico GPIO includes the following features:

- ▶ WISHBONE B.3 interface
- ▶ WISHBONE data base size configurable to 8 or 32 bits wide
- ▶ Four transfer port types: tristate, input, output, independent input/output
- ▶ Interrupt request (IRQ) generation on level-sensitive or edge-sensitive input
- ▶ Hardware interrupt mask register

Figure 1 shows the deployment of the LatticeMico GPIO within the FPGA and its input and output ports.

For additional details about the WISHBONE bus, refer to the *LatticeMico8 Processor Reference Manual* or the *LatticeMico32 Processor Reference Manual*.

Figure 1: Using GPIO to Connect LatticeMico to FPGA I/O Pins

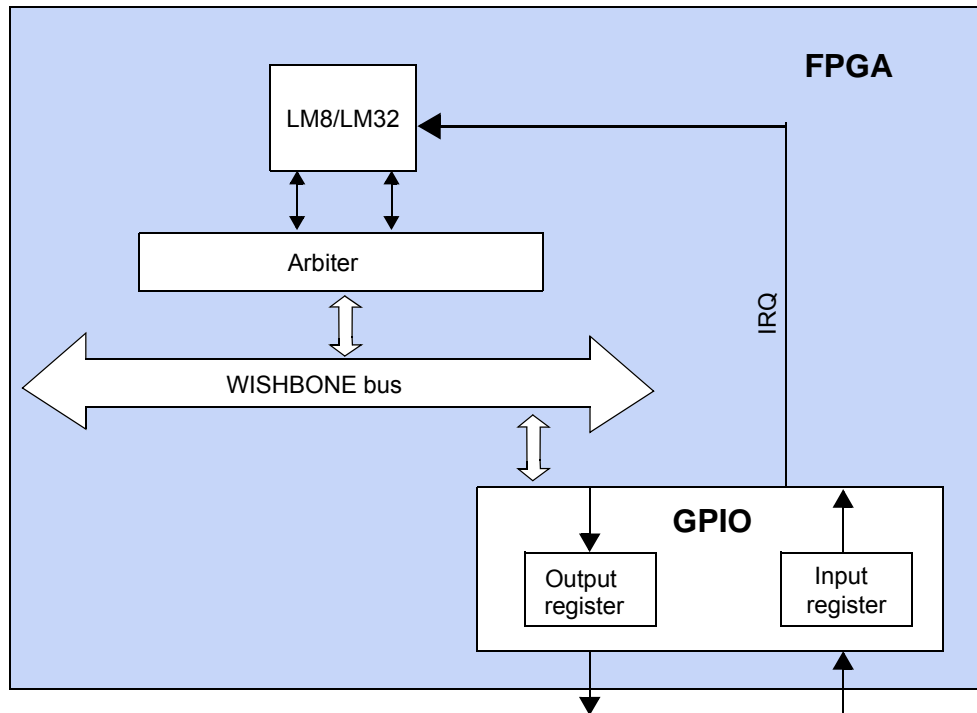

Functional Description

The LatticeMico GPIO creates an interface between the LatticeMico RISC processor and a simple bit-level control interface. The control bits can be connected to either internal or external logic. Control of the input or output pins is managed using four memory-mapped registers. The memory-mapped registers control reading and writing the input/output bits, tristating the I/O bits, interrupt masking, and an “edge event” status register.

The number, width, and behavior of the control registers change on the basis of the configuration of the GPIO block. The GPIO block can be configured with inputs only, outputs only, or both inputs and outputs. A bidirectional mode with tristate control is also provided for bidirectional I/O pins that are available on the device. Bidirectional mode I/O can only be connected to FPGA I/O pins. They are not available for use with on-chip logic.

Reading the data register returns the value that is present on the input ports. See “EBR Resource Utilization” on page 14 for details. Writing the PIO_DATA register (see Table 4 on page 10) affects the value that is driven to the output ports. Because these ports are independent, reading the data register does not return the previously written data. Bidirectional ports, which are tristate, are the exception to this behavior.

Figure 2 is an internal block diagram of the GPIO showing its bidirectional ports. It shows how the PIO_TRI register (see Table 4) determines whether the PIO_DATA register is used to transfer data in or out.

Figure 2: LatticeMico GPIO Core Usage with Bidirectional Ports

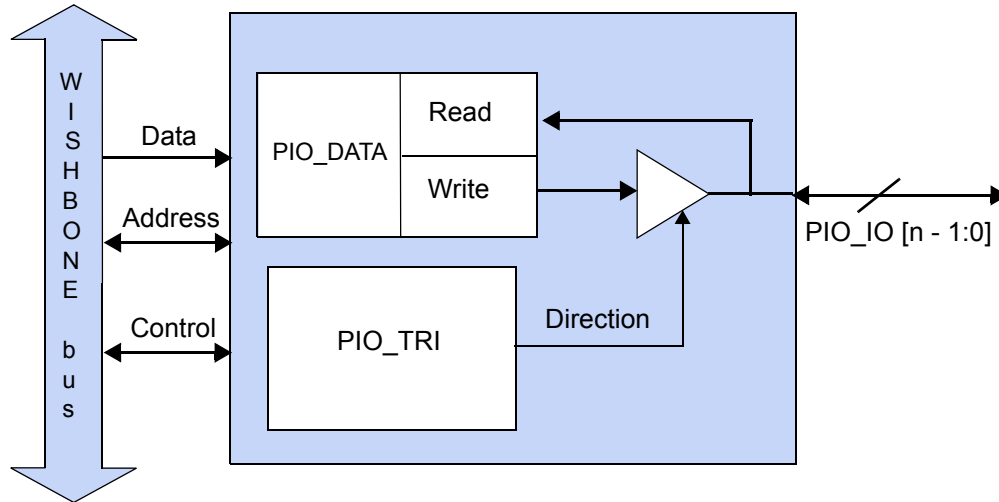

Input Data Path

Figure 6 on page 13 shows how the GPIO's master ports read the data in the internal register. The input port is connected to a D flip-flop that has an asynchronous reset controlled by RST_I. The flip-flop is continuously clocked by CLK_I. The output is connected directly to the PIO_DATA read register, as shown in Figure 2. The value read from the PIO_DATA register is always delayed one CLK_I cycle from the current state of the PIO_IN port. The PIO_DATA read cycle does not prevent the input flip-flop from changing state.

Output Data Path

The PIO_OUT is driven by D-type flip-flops. The D-type flip-flops are updated when the processor writes to the PIO_DATA register. The data appears on the output pins when the WISHBONE acknowledge signal (GPIO_ACK_O) goes high.

Tristate Control

After the microprocessor writes to the PIO_TRI register, the pins are tristated when the WISHBONE acknowledge signal (GPIO_ACK_O) goes high. The data becomes valid in the same cycle as the GPIO_ACK_O.

Edge Capture

The edge capture register is used to produce an interrupt, which corresponds to the input bit where the edge was detected. The edge capture register is read to identify which input bit caused the interrupt. If an edge capture interrupt is not cleared, subsequent edge events on the same input bit will be ignored. See “IRQ Generation” on page 5 for more information on interrupt request priorities.

You can configure the GPIO to capture edges on the input ports. The type of edges—which can include low-to-high transitions, high-to-low transitions, or both—are defined and configured at the time that the processor platform is generated. It is not possible to change the edge capture behavior at run time. When an edge is detected by the input, the condition is indicated in the edge capture register. The bit position corresponding to the input pin transitions from 0 to 1.

The edge is detected when the input signal transitions between two WISHBONE clock cycles (CLK_I).

Clearing a bit—that is, setting it to zero in the edge capture register—clears the corresponding bit in the edge capture register. Setting a bit in the interrupt mask register resets the corresponding bit in the edge capture register if it was set.

Port Width and Port Type Settings

The Width and Port Type settings define the basic functionality of the GPIO instance.

Port Width

The number of I/O pins that can be controlled by the GPIO block ranges from a minimum of one to a maximum of thirty-two. In the case of the mixed independent input/output ports, the number of input ports can be different than the number of output ports.

Port Type

The GPIO instance can be configured for output only, input only, mixed independent input/output, and shared bidirectional input/output.

Output Port Type For the output port type, the PIO ports can drive output only (PIO_OUT).

Input Port Type For the input port type, the PIO ports can capture input only (PIO_IN).

Independent Input and Output Port Type For the independent input and output port type, the input and output ports are separate unidirectional buses. The number of input pins can be set independently of the number of output ports. The PIO_DATA register is wide enough to manage the larger of the “Input Width” or “Output Width.” The input and output bits overlap in the PIO_DATA register, starting at the least-significant bit. The “Input Width” PIO_IN ports and “Output Width” PIO_OUT ports are created for connection to logic external to the GPIO block.

Tristate Port Type For the tristate port type, each PIO bit shares one device pin for driving and capturing data. The direction of each pin is individually selectable. An I/O pin becomes an input when the corresponding PIO_TRI register bit is cleared, that is, 0. Whenever the WISHBONE RST_I signal is asserted, the PIO_TRI register is cleared, forcing all PIO_IO pins to be inputs.

IRQ Generation

You can configure the LatticeMico GPIO to generate an interrupt request (IRQ) on level-sensitive or edge-sensitive input conditions.

- ▶ Level-sensitive – An IRQ is generated whenever a specific input is high and interrupt requests are enabled for that input in the IRQ_MASK register. The input pin should be held high until the interrupt condition is cleared.
- ▶ Edge-sensitive – An IRQ is generated whenever a specific bit in the edge capture register is high and interrupt requests are enabled for that bit in the IRQ_MASK register. The type of edge must be specified at platform generation: positive edge, negative edge, or either edge. Clearing a bit—that is, setting it to zero in the edge capture register—clears the corresponding bit in the edge capture register. Setting a bit in the interrupt mask register resets the corresponding bit in the edge capture register if it was set.

Any I/O in a GPIO can cause an interrupt request. The IRQ_MASK register of the GPIO defines which I/Os can cause an interrupt request.

When the IRQ mode is turned off, the IRQ_MASK register does not exist.

Figure 3 shows a bidirectional LatticeMico GPIO similar to that shown in Figure 2 but with the ability to generate interrupt requests. The GPIO in Figure 3 can generate interrupt requests as a signal switches from 0 to 1 or 1 to 0 (edge capture).

Note

The GPIO interrupt generation logic is synchronized to the WISHBONE clock. In order to ensure that the interrupt generation logic can capture a 0 to 1 or 1 to 0 transition, the external logic driving the GPIO line must ensure that the 1 to 0 or 0 to 1 transition is valid for at least one WISHBONE clock. If the GPIO line transitions, for example, from 1 to 0 and back to 1 before a WISHBONE clock edge, then the interrupt will not be generated because the 1 to 0 edge was not captured.

Figure 3: LatticeMico GPIO Usage with IRQ (Edge Capture)

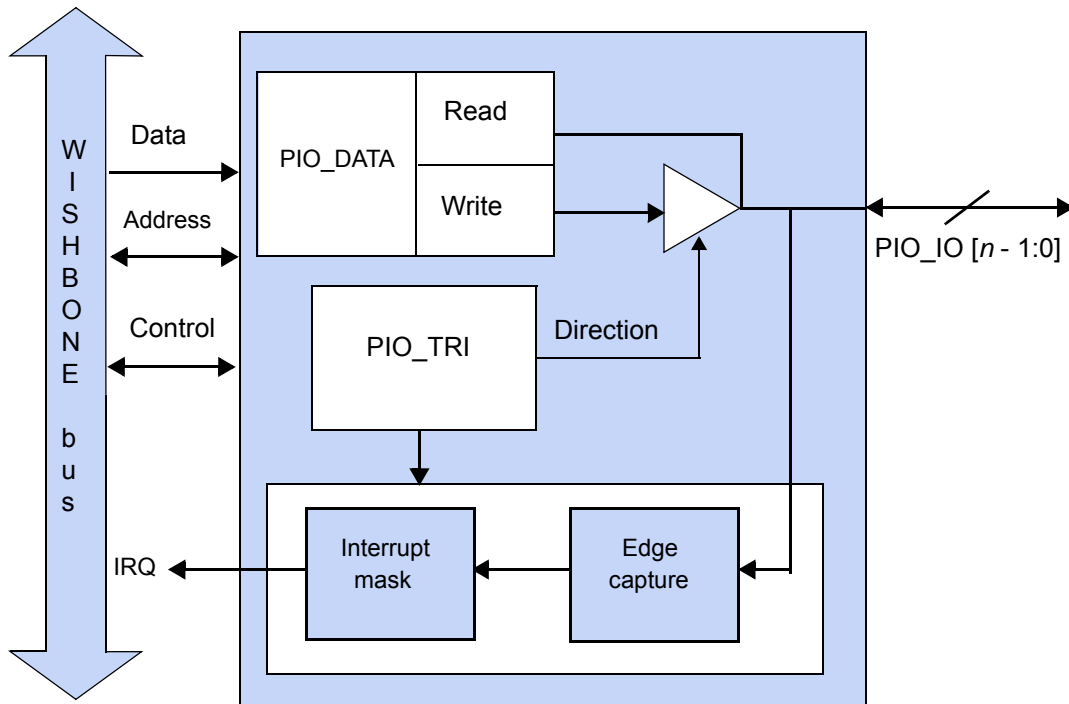

For level-sensitive input, as shown in Figure 4, only active high is directly supported.

Configuration

The following sections describe the graphical user interface (UI) parameters, the hardware description language (HDL) parameters, and the I/O ports that you can use to configure and operate the LatticeMico GPIO.

UI Parameters

Table 1 shows the UI parameters available for configuring the LatticeMico GPIO through the Mico System Builder (MSB) interface.

HDL Parameters

Table 2 describes the parameters that appear in the HDL.

I/O Ports

Table 3 describes the input and output ports of the LatticeMico GPIO.

User Impact of Initial State

For the output port, the initial state is low after reset.

Figure 4: LatticeMico GPIO Usage with IRQ (Level Triggered)

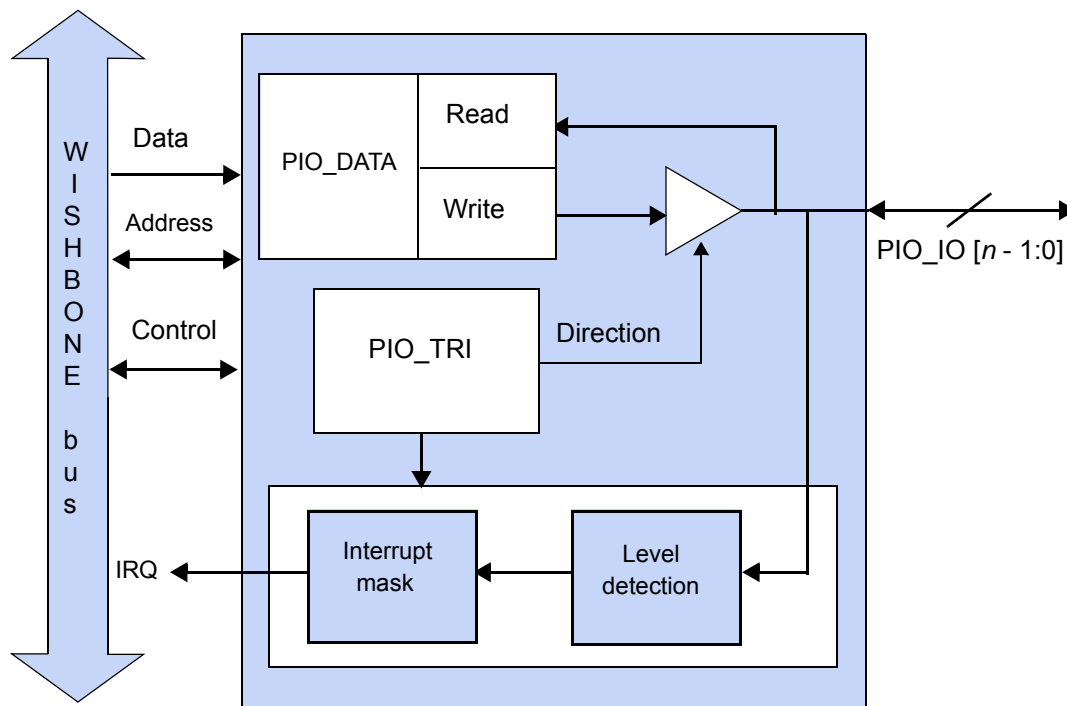

Table 1: GPIO UI Parameters

Dialog Box Option	Description	Allowable Values	Default Value
Instance Name	Specifies the name of the GPIO instance.	Alphanumeric and underscores	gpio
Base Address	Specifies the base address for the device. The minimum byte alignment is 0X80.	0X80000000 – 0XFFFFFF80 If other components are included in the platform, the range of allowable values will vary.	0X80000000

Port Types

Output Ports Only	Specifies the transfer mode of PIO ports as output only.	selected not selected	selected
Input Ports Only	Specifies the transfer mode of PIO ports as input only.	selected not selected	not selected
Tristate Ports	Specifies the transfer mode of PIO ports as tristate only.	selected not selected	not selected
Both Input and Output	Specifies the transfer mode of PIO ports as input and output.	selected not selected	not selected

Port Width

Data Width	Specifies the width of the I/O port, in bits.	1 to 32	1
------------	---	---------	---

Table 1: GPIO UI Parameters (Continued)

Dialog Box Option	Description	Allowable Values	Default Value
Input Width	Specifies the input data bus width for an independent input/output GPIO, in bits.	1 to 32	1
Output Width	Specifies the output data bus width for an independent input/output GPIO, in bits.	1 to 32	1
IRQ Mode			
IRQ Mode	When selected, provides IRQ signal output when a specified event occurs on input ports	selected not selected	not selected
Level	When selected, generates an IRQ whenever a specific input is high and interrupts have been enabled for that input in the IRQ-MASK register.	selected not selected	not selected
Edge	When selected, generates an IRQ whenever a specific bit in the edge capture register is high and interrupts have been enabled for that bit in the IRQ-MASK register.	selected not selected	selected
Edge Response			
Either Edge	When selected, generates an IRQ on either low-to-high or high-to-low transitions.	selected not selected	not selected
Positive Edge	When selected, generates an IRQ on low-to-high transitions.	selected not selected	selected
Negative Edge	When selected, generates an IRQ on high-to-low transitions.	selected not selected	not selected
WISHBONE Configuration			
WISHBONE Data Bus Width	Specifies the WISHBONE data bus width in bits	8, 32	32

Table 2: GPIO HDL Parameters

Parameter Name	Description	Allowable Values
GPIO_WB_ADR_WIDTH	Defines the width of WISHBONE Address Bus	8 32
GPIO_WB_DAT_WIDTH	Defines the width of WISHBONE Data Bus	8 32
INPUT_PORTS_ONLY	A value of 1 defines the transfer mode for PIO ports as input only.	0 1
OUTPUT_PORTS_ONLY	A value of 1 defines the transfer mode for PIO ports as output only.	0 1
TRISTATE_PORTS	A value of 1 defines the transfer mode for PIO ports as tristate only.	0 1

Table 2: GPIO HDL Parameters (Continued)

Parameter Name	Description	Allowable Values
BOTH_INPUT_AND_OUTPUT	A value of 1 defines the transfer mode for PIO ports as input and output.	0 1
DATA_WIDTH	Defines the width of the I/O port.	1 to 32
INPUT_WIDTH	Defines the input data bus width for an independent input/output GPIO.	1 to 32
OUTPUT_WIDTH	Defines the output data bus width for an independent input/output GPIO.	1 to 32
IRQ_MODE	A value of 1 establishes IRQ_MODE, providing IRQ signal output when a specified event occurs on input ports.	0 1
LEVEL	With a value of 1, an IRQ is generated whenever a specific input is high and interrupts have been enabled for that input in the IRQ MASK register.	0 1
EDGE	With a value of 1, an IRQ is generated whenever a specific bit in the edge capture register is high and interrupts have been enabled for that bit in the IRQ MASK register.	0 1
EITHER_EDGE_IRQ	With a value of 1, an IRQ is generated on either low-to-high or high-to-low transitions.	0 1
POSE_EDGE_IRQ	With a value of 1, an IRQ is generated on low-to-high transitions.	0 1
NEGE_EDGE_IRQ	With a value of 1, an IRQ is generated on high-to-low transitions.	0 1

Table 3: GPIO I/O Ports

Port Name	Active	Direction	Initial State	Description
System Clock and Reset				
CLK_I	—	I	X	System clock
RST_I	High	I	X	System reset
WISHBONE Interface				
GPIO_ADR_I	—	I	X	Address input array, the address generated by the master
GPIO_CYC_I	High	I	X	Cycle input. When asserted, it indicates that a bus cycle is in progress.
GPIO_DAT_I	—	I	X	Data input array, valid for a write request
GPIO_LOCK_I	High	I	X	Lock input. If asserted, the current cycle becomes uninterruptible.
GPIO_SEL_I	High	I	X	Select input array, which indicates where the valid data is expected on a data bus.

Table 3: GPIO I/O Ports (Continued)

Port Name	Active	Direction	Initial State	Description
GPIO_STB_I	High	I	X	Strobe input. When asserted, indicates that the SLAVE is selected.
GPIO_WE_I	—	I	X	Write signal. Value of 1 is used for a write and 0 for a read.
GPIO_ACK_O	High	O	0	Acknowledge output. When asserted, indicates normal cycle termination.
GPIO_DAT_O	—	O	0	Data output array
PIO Interface Ports				
PIO_IN	—	I	X	Appears in input mode or both input and output mode. The GPIO's number of input bits is configurable.
PIO_OUT	—	O	0	Appears in output mode or both input and output mode. The GPIO's number of output bits is configurable.
PIO_IO	—	I/O	0/X	Appears in tristate mode only. Each GPIO bit shares one device pin for driving and capturing data. The direction of each pin is individually selectable. The PIO_IO is an input when the corresponding PIO_TRI register bit is cleared (0).
Other Auto-connected Internal Signals				
IRQ_O	High	O	0	Interrupt request outputs. The GPIO can be configured to generate an IRQ on certain input conditions.

Register Definitions

The LatticeMico GPIO includes the registers shown in Table 4. See [“Software Usage Examples” on page 21](#) for examples that show how to access these registers in order to access the programmable I/O pins.

Table 4: Register Map

Register Name	Offset	Address Offset within Register Word				Description
		0x0	0x1	0x2	0x3	
PIO_DATA	0x00	PIO_IN/OUT/ IO[7:0]	PIO_IN/OUT/ IO[15:8]	PIO_IN/OUT/ IO[23:16]	PIO_IN/OUT/ IO[31:24]	I/O Data
PIO_TRI	0x04	[7:0]	[15:8]	[23:16]	[31:24]	Tristate control
IRQ_MASK	0x08	[7:0]	[15:8]	[23:16]	[31:24]	IRQ Mask
EDGE_CAPTURE	0x0C	[7:0]	[15:8]	[23:16]	[31:24]	Edge Capture

Table 5 through Table 8 provide details about each register in the LatticeMico GPIO.

Table 5: PIO_DATA Register Bit Definition

Register Name	Bit	Access Mode	Description
PIO_DATA	DATA_WIDTH -1:0	Read/Write	<p>R – Input and I/O data latched and read</p> <p>W – Output and I/O data asserted</p> <p>R/W – Bidirectional I/O data read/written</p> <p>Example: Reading a byte from address offset 0 will latch and read in value from PIO_IN[7:0] or PIO_IO[7:0]</p> <p>Example: Reading a word from address offset 0 will latch and read in a value from {PIO_IN[31:24],PIO_IN[23:16], PIO_IN[15:8],PIO_IN[7:0]} or {PIO_IO[31:24], PIO_IO[23:16],PIO_IO[15:8],PIO_IO[7:0]}</p>

Table 6: PIO_TRI Register Bit Definition

Register Name	Bit	Access Mode	Description
PIO_TRI	DATA_WIDTH -1:0	Read/Write	<p>This is the PIO read/write tristate enable mask.</p> <p>Setting a bit to 1 puts the corresponding PIO_IO pin in output mode.</p> <p>Setting a bit to 0 puts the corresponding PIO_IO pin in input mode.</p> <p>Example: Writing a byte 0xFF to address offset 3 will put PIO_IO[31:24] pins in output mode.</p>

Table 7: IRQ_MASK Register Bit Definition

Register Name	Bit	Access Mode	Description
IRQ_MASK	DATA_WIDTH -1:0	Read/Write	<p>This enables/disables interrupt generation and clears the EDGE_CAPTURE register.</p> <p>Setting a bit to 1 enables interrupt generation for the corresponding PIO_IN/IO pin.</p> <p>Setting a bit to 0 disables interrupt generation for the corresponding PIO_IN/IO pin.</p> <p>A change from 0 to 1 clears the corresponding EDGE_CAPTURE register.</p> <p>Example: Writing a word 0xFF000000 to address offset 0 will enable interrupt generation for PIO_IN/IO[7:0] and disable it for PIO_IN/IO[31:8]</p>

Table 8: EDGE_CAPTURE Register Bit Definition

Register Name	Bit	Access Mode	Description
EDGE_CAPTURE	DATA_WIDTH -1:0	Read/Write	<p>A bit that is set to 1 indicates that an edge capture event has occurred for that input port.</p> <p>The bit is cleared by writing a 0 to the corresponding bit in the EDGE_CAPTURE register or by disabling and then enabling the corresponding bit in the IRQ_MASK register.</p> <p>After an edge is detected, the EDGE_CAPTURE bit is held at 1 until explicitly cleared.</p> <p>Example: If a byte read from address offset 0 returns 0x01, then an edge capture event occurred for PIO_IN/IO[0]</p>

Timing Diagrams

The timing diagrams featured in Figure 5 through Figure 9 show the timing of the GPIO's WISHBONE and external signals.

Figure 5 shows how the GPIO's master ports update the data in the internal register.

Figure 5: WISHBONE Master Writes Data in the Internal Register

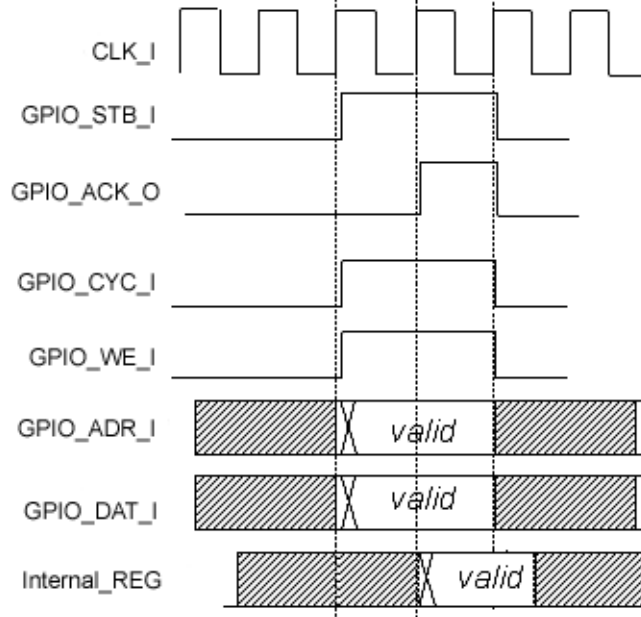

Figure 6 shows how the GPIO's master ports read the data in the internal register.

Figure 6: WISHBONE Master Reads Data in the Internal Register

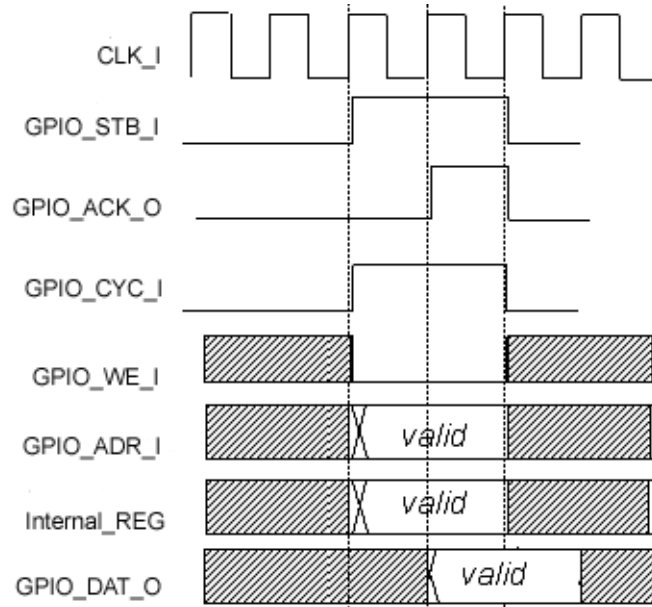

Figure 7 shows how the GPIO generates interrupt requests when a signal is high or low.

Figure 7: IRQ Generation (Level)

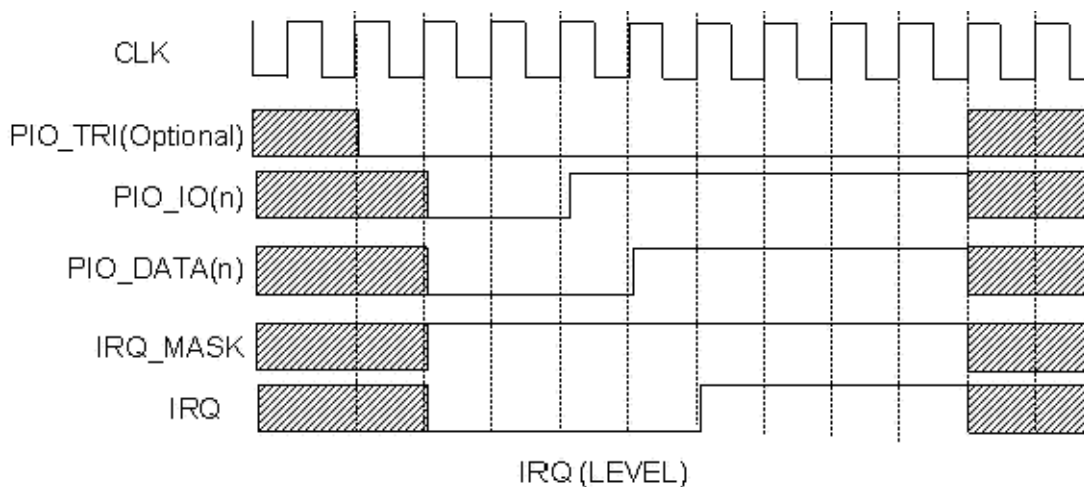

Figure 8 shows how the GPIO generates interrupt requests when the PIO_DATA signal transitions from low to high. After an edge is detected, the Edge_Capture bit is held at a 1 until cleared in the IRQ_MASK register.

Figure 8: IRQ Generation (Rising Edge)

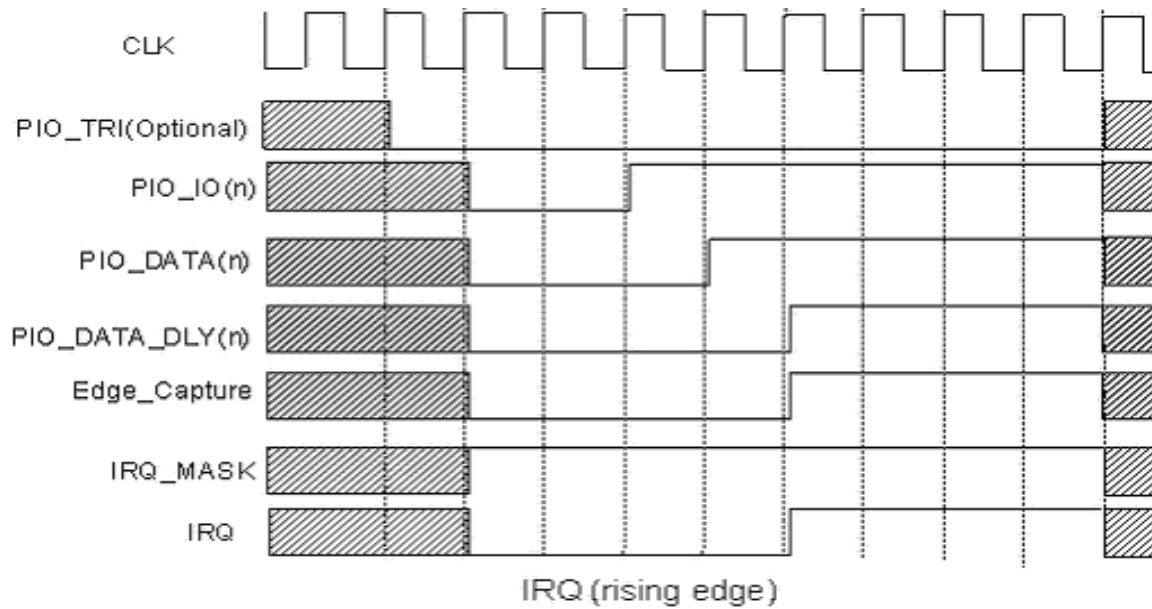
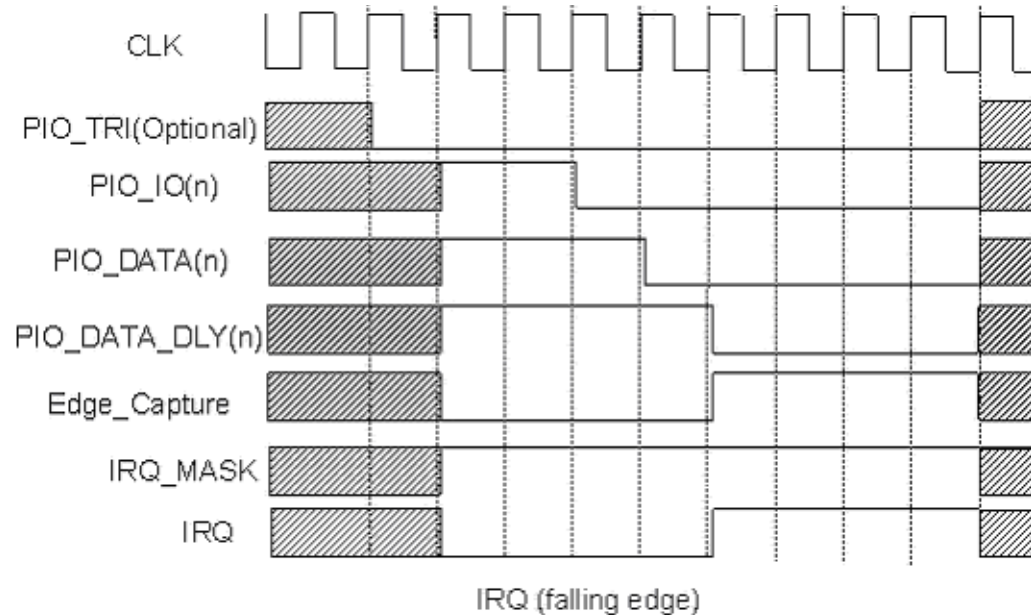

Figure 9 shows how the GPIO generates interrupt requests when the PIO_DATA signal transitions from high to low.

Figure 9: IRQ Generation (Falling Edge)



EBR Resource Utilization

The LatticeMico GPIO uses no EBRs.

LatticeMico32 Microprocessor Software Support

This section describes the software support provided for the LatticeMico GPIO component, including the GPIO usage model, its relationship with the LatticeMico32 microprocessor, the device driver, and services. It also provides software usage examples.

The support routines for the GPIO component are for use in a single-threaded environment. If used in a multi-tasking environment, re-entrance protections must be provided.

Usage Model

The GPIO component, as the name suggests, is general-purpose. This component can be used for the following:

- ▶ An output device (output mode only)
- ▶ An input device (input mode only)
- ▶ An output and input device (output and input mode), which means using separate input and output pins
- ▶ A bidirectional device, which means that the same sets of pins are used for input and output by controlling the direction of the pins

Additionally, this device is capable of generating interrupt requests when the following are detected on an input port:

- ▶ High level
- ▶ Positive edge
- ▶ Negative edge

The usage scenario depends on the end-user application and does not fit within a well-known usage model. To handle interrupt from a GPIO that is configured to trigger interrupts on edge detection, you can disable the interrupt and perform processing later, since the edge-capture register remains set on detecting the appropriate condition. Or, you can perform the processing in the ISR and write a zero to the corresponding bit of the edge-capture register to clear the condition. In the former case, the edge-capture register is cleared when the interrupt is enabled again; in the latter case, the edge-capture register is explicitly cleared by writing a zero to the corresponding bit of the edge-capture register.

Effect of Endianness

LatticeMico32 is a big-endian microprocessor. Therefore, it is important to understand the impact of endianness when the microprocessor interacts with the component's registers. In a big-endian architecture, the most-significant byte of a multi-byte object is stored at the lowest address, and the least-significant byte of that object is stored at the highest address.

Assume that you have a design that contains a 32-bit GPIO that has been assigned a base address of 0x80000100. The GPIO data register for input and output of data is located at offset 0 from the base address. Byte 0 (bits 7-0) of this GPIO data register is located at byte offset 0 (address 0x80000100), while byte 3 (bits 31-24) is located at byte offset 3 from the base address (0x800001003). Lets assume that the GPIO has received a value [31:0] = 32'h12345678 and the programmer is writing C code to read the 32-bit GPIO.

Figure 10 shows a sample code to read the 32-bit GPIO using byte reads (i.e., "unsigned char" or "signed char").

Figure 10: Access to a 32-bit GPIO using byte reads

```
unsigned char byte0, byte1, byte2, byte3;
byte0 = *(volatile unsigned char *)0x80000100;
byte1 = *(volatile unsigned char *)0x80000101;
byte2 = *(volatile unsigned char *)0x80000102;
byte3 = *(volatile unsigned char *)0x80000103;
```

The execution of the code in Figure 10 will result in byte0 = 0x78, byte1 = 0x56, byte2 = 0x34, and byte3 = 0x12.

Now consider the sample code of Figure 11 in which the programmer is reading the same 32-bit GPIO using word reads ("unsigned int" or "signed int").

Figure 11: Access to a 32-bit GPIO using word reads

```
unsigned int word;
word = *(volatile unsigned int *)0x80000100;
```

As mentioned, LatticeMico32 is a big-endian microprocessor. Therefore, from the programmer's perspective, the least-significant byte of the GPIO will appear in the most-significant location. The execution of the code in Figure 11 will result in 'word' being loaded with a value of 0x78563412.

Register Map Structure

The structure shown in Figure 5 depicts the register map layout for the GPIO component. The elements are self-explanatory and are based on the register, as shown in Table 4 on page 10. This structure, which is defined in the MicoGPIO.h header file, enables you to directly access the GPIO registers, if desired. It is used internally by the device driver for manipulating the GPIO.

Figure 12: GPIO Register Map Structure

```

/*
 * GPIO REGISTER MAPPING
 */
typedef struct st_MicoGPIO_t{
/* read/write: r-only for in-only GPIO, w-only for out-only
GPIO, r/w for tristates */
volatile unsigned int data;
/* read/write: tristate enable register for tristate GPIOs
*/
volatile unsigned int tristate;
/* read/write: sets irq mask for interrupt-enabled GPIOs */
volatile unsigned int irqMask;
/* read/write: applicable to GPIOs with edge-capture
capability */
volatile unsigned int edgeCapture;
}MicoGPIO_t;

```

Device Driver

This section describes the type definitions for instance-specific structures and the GPIO device context structure.

Instance-Specific Structures

The MSB managed build process instantiates a unique structure per instance of the GPIO in the platform. These instances are defined in DDStructs.c. The information for these instance-specific structures is filled in by the managed build process, which extracts GPIO component-specific information from the platform definition file. The members should not be manipulated directly because the structure is used exclusively by the device driver. You can retrieve a pointer to the instance-specific GPIO device context structure by using the MicoGetDevice function call of the LatticeMico32 device lookup service. Refer to the *LatticeMico32 Software Developer User Guide* for more information on the device lookup service.

GPIO Device Context Structure

This structure, shown in Figure 13, contains GPIO component-specific information and is dynamically generated in the DDStructs.h header file. This information is largely filled in by the MSB managed build process, which extracts the GPIO component-specific information from the platform definition file. The members should not be manipulated directly, because this structure is for exclusive use by the device driver.

Figure 13: GPIO Device Context Structure

```

typedef struct st_MicoGPIOctx_t {
    const char*    name;
    unsigned int   base;
    unsigned int   intrLevel;
    unsigned int   output_only;
    unsigned int   input_only;
    unsigned int   in_and_out;
    unsigned int   tristate;
    unsigned int   data_width;
    unsigned int   input_width;
    unsigned int   output_width;
    unsigned int   intr_enable;
    unsigned int   wb_data_size;
    DeviceReg_t    lookupReg;
    void *         prev;
    void *         next;
} MicoGPIOctx_t;

```

Table 9 describes the parameters of the GPIO device context structure shown in Figure 13.

Table 9: GPIO Device Context Structure Parameters

Parameter	Data Type	Description
name	const char *	GPIO instance name
base	unsigned int	MSB-assigned base address
intrLevel	unsigned int	MSB-assigned interrupt, if interrupts are used. If interrupts are not used, this value is greater than 31. If interrupts are used, the value is 0-31.
output_only	unsigned int	This value is 1 if the GPIO is configured as output only. Otherwise, it is 0.
input_only	unsigned int	This value is 1 if the GPIO is configured as input only. Otherwise, it is 0.
in_and_out	unsigned int	This value is 1 if the GPIO is configured as input and output. Otherwise, it is 0.
tristate	unsigned int	This value is 1 if the GPIO is configured as a tristate device. It is 0 if the GPIO is not configured as a tristate device.
data_width	unsigned int	This value represents the instance-configured data width. It should be treated as a valid value only if the GPIO is configured as input only, output only, or tristate only.
input_width	unsigned int	This value represents the input width if the GPIO is configured for input and output mode.
output_width	unsigned int	This value represents the output width if the GPIO is configured for input and output mode.

Table 9: GPIO Device Context Structure Parameters (Continued)

Parameter	Data Type	Description
intr_enable	unsigned int	This value is set to 0 if the GPIO is not configured to generate interrupts. Otherwise, the value is 1.
wb_data_size	unsigned int	This value determines the width of the WISHBONE data bus. Allowed values are 8 or 32.
lookupReg	DeviceReg_t	Used by the device driver to register the GPIO component instance with the LatticeMico32 lookup service. Refer to the <i>LatticeMico32 Software Developer User Guide</i> for a description of the DeviceReg_t data type.
prev	void *	Used internally by the lookup service
next	void *	Used internally by the lookup service

Note

You may need to access the GPIO device registers directly, but some of these registers are write-only. Implementing shadow registers in RAM can be an effective way to replace this missing capability. Figure 14 provides an example of “shadow” register code for handling write-only registers in LatticeMico System.

Figure 14: Example Shadow Register Code Fragment

```
MicoGPIOctx_t *pGPIO_context;
MicoGPIO_t     gpioState, *pGPIO;

// The GPIO is an OUTPUT only instance
pGPIO = (pMicoGPIO_t *) (pGPIO_context->base);
// initialize the "shadow" copy in RAM
gpioState.gpioData = 0x1ff;
// write the "shadow" values out to the I/O pins
pGPIO->gpioData = gpioState.gpioData;

// do a read of the "shadow" value and then clear the lsb
gpioState->gpioData &= 0xFE;
// write the new value to the I/O pins
pGPIO->gpioData = pGpioState->gpioData;
// ...
```

Functions

Since the GPIO is a general-purpose device and does not fit a well-defined usage scenario, there are no predefined functions. However, there are numerous macros provided in the MicoGPIO.h file that allow easy access to the various GPIO registers using the GPIO context structure. These macros are listed here, and their usage is illustrated in “Software Usage Examples” on page 21.

Figure 15: Macros for Accessing GPIO Registers

```

/*
 * MACROS FOR ACCESSING GPIO REGISTERS
 *
 * NOTE: For the macros, the following rules apply:
 * X is a pointer to a valid MicoGPIOctx_t structure.
 * Y is an unsigned int variable.
 */

/* reads data register */
#define MICO_GPIO_READ_DATA(X,Y) \
    (Y)=((volatile MicoGPIO_t *)((X)->base))->data

/* writes data-register */
#define MICO_GPIO_WRITE_DATA(X,Y) \
    ((volatile MicoGPIO_t *)((X)->base))->data=(Y)

/* reads tristate register */
#define MICO_GPIO_READ_TRISTATE(X,Y) \
    (Y) = ((volatile MicoGPIO_t *)((X)->base))->tristate

/* writes tristate register */
#define MICO_GPIO_WRITE_TRISTATE(X,Y) \
    ((volatile MicoGPIO_t *)((X)->base))->tristate = (Y)

/* reads irq-mask register */
#define MICO_GPIO_READ_IRQ_MASK(X,Y) \
    (Y) = ((volatile MicoGPIO_t *)((X)->base))->irqMask

/* writes irq-mask register */
#define MICO_GPIO_WRITE_IRQ_MASK(X,Y) \
    ((volatile MicoGPIO_t *)((X)->base))->irqMask = (Y)

/* reads edge-capture register */
#define MICO_GPIO_READ_EDGE_CAPTURE(X,Y) \
    (Y) = ((volatile MicoGPIO_t *)((X)->base))->edgeCapture

/* writes to the edge-capture register */
#define MICO_GPIO_WRITE_EDGE_CAPTURE(X,Y) \
    ((volatile MicoGPIO_t *)((X)->base))->edgeCapture = (Y)

```

Services

The GPIO device driver registers GPIO instances with the LatticeMico32 lookup service, using their instance names for device names and “GPIODevice” as the device type.

For more information about using the lookup service, refer to the *LatticeMico32 Software Developer User Guide*.

Software Usage Examples

This section provides two code examples that demonstrate how to access the GPIO registers.

Using the GPIO Register Structure

The code example shown in Figure 16 shows how to locate a GPIO device, with 32 programmable I/Os, that is instantiated in the platform and how to directly access the registers using the GPIO register structure.

Figure 16: Locating a GPIO and Accessing Its Registers

```

/* Fetch GPIO instance named "LED" */
volatile MicoGPIO_t *pGPIO;
MicoGPIOCtx_t *leds = (MicoGPIOCtx_t *)MicoGetDevice("led");
if(leds == 0) {
    /* failed to find a component named "leds" */
    return(-1);
}

/* get access to the GPIO registers */
pGPIO = (volatile MicoGPIO_t *) (leds->base);

/* write 0x80 to programmable I/O pins 7 through 0 via the data
register. */
pGPIO->data = 0x80000000;

```

Using Provided Macros

The code example shown in Figure 17 shows how to locate a GPIO device that is instantiated in the platform and how to directly access the data register using the macros provided in MicoGPIO.h header file.

Figure 17: Locating a GPIO and Accessing Its Data Register

```

/* Fetch GPIO instance named "LED" */
unsigned int iValue;
MicoGPIOCtx_t *leds = (MicoGPIOCtx_t *)MicoGetDevice("led");
if (leds == 0) {
    /* failed to find a component named "leds" */
    return(-1);
}

```

Figure 17: Locating a GPIO and Accessing Its Data Register

```
/* write 0x80 to programmable I/O pins 7 through 0 via the data
register. */
MICO_GPIO_WRITE_DATA(leds, 0x80000000);

/* read back the value in the data register */
MICO_GPIO_READ_DATA(leds, iValue);
```

LatticeMico8 Microcontroller Software Support

This section describes the software support provided for the LatticeMico GPIO component, its relationship with the LatticeMico8 microcontroller, the device driver, and services. It also provides software usage examples.

The support routines for the GPIO component are for use in a single-threaded environment. If used in a multi-tasking environment, re-entrance protections must be provided.

Device Driver

This section describes the type definitions for instance-specific structures and the GPIO device context structure.

Instance-Specific Structures

The MSB managed build process instantiates a unique structure per instance of the GPIO in the platform. These instances are defined in DDStructs.c. The information for these instance-specific structures is filled in by the managed build process, which extracts GPIO component-specific information from the platform definition file. The members should not be manipulated directly because the structure is used exclusively by the device driver.

GPIO Device Context Structure

This structure, shown in Figure 13, contains GPIO component-specific information and is dynamically generated in the DDStructs.h header file. This information is largely filled in by the MSB managed build process, which extracts the GPIO component-specific information from the platform definition file. The members should not be manipulated directly, because this structure is for exclusive use by the device driver.

Figure 18 shows the GPIO device context structure. Figure 10 describes the parameters of the GPIO device context structure shown in Figure 18.

Figure 18: GPIO Device Context Structure

```

const char*   name;
    size_t    base;
    unsigned char   intrLevel;
    unsigned char   output_only;
    unsigned char   input_only;
    unsigned char   in_and_out;
    unsigned char   tristate;
    unsigned char   data_width;
    unsigned char   input_width;
    unsigned char   output_width;
    unsigned char   intr_enable;

```

Table 10: GPIO Device Context Structure Parameter

Parameter	Data Type	Description
name	const char *	GPIO instance name
base	size_t	MSB-assigned base address
intrLevel	unsigned char	MSB-assigned interrupt, if interrupts are used. If interrupts are not used, this value is greater than 7. If interrupts are used, the value is 0-7.
output_only	unsigned char	This value is 1 if the GPIO is configured as output only. Otherwise, it is 0.
input_only	unsigned char	This value is 1 if the GPIO is configured as input only. Otherwise, it is 0.
in_and_out	unsigned char	This value is 1 if the GPIO is configured as input and output. Otherwise, it is 0.
tristate	unsigned char	This value is 1 if the GPIO is configured as a tristate device. It is 0 if the GPIO is not configured as a tristate device.
data_width	unsigned char	This value represents the instance-configured data width. It should be treated as a valid value only if the GPIO is configured as input only, output only, or tristate only.
input_width	unsigned char	This value represents the input width if the GPIO is configured for input and output mode.
output_width	unsigned char	This value represents the output width if the GPIO is configured for input and output mode.
intr_enable	unsigned char	This value is set to 0 if the GPIO is not configured to generate interrupts. Otherwise, the value is 1.

Functions

Since the GPIO is a general-purpose device and does not fit a well-defined usage scenario, there are no predefined functions. However, there are

numerous macros provided in the MicoGPIO.h file that allow easy access to the various GPIO registers using the GPIO context structure. These macros are listed in Figure 19.

Figure 19: Macros for Accessing Each Byte of the Data Register

```
#define MICO_GPIO_READ_DATA_BYTE0(X, Y) \  
    (Y) = (__builtin_import((size_t)(X+GPIO_DATA_OFFSET+0)))  
  
#define MICO_GPIO_READ_DATA_BYTE1(X, Y) \  
    (Y) = (__builtin_import((size_t)(X+GPIO_DATA_OFFSET+1)))  
  
#define MICO_GPIO_READ_DATA_BYTE2(X, Y) \  
    (Y) = (__builtin_import((size_t)(X+GPIO_DATA_OFFSET+2)))  
  
#define MICO_GPIO_READ_DATA_BYTE3(X, Y) \  
    (Y) = (__builtin_import((size_t)(X+GPIO_DATA_OFFSET+3)))  
  
/* Macros for writing each byte of the Data Register */  
#define MICO_GPIO_WRITE_DATA_BYTE0(X, Y) \  
    (__builtin_export((char)(Y),  
    (size_t)(X+GPIO_DATA_OFFSET+0)))  
  
#define MICO_GPIO_WRITE_DATA_BYTE1(X, Y) \  
    (__builtin_export((char)(Y),  
    (size_t)(X+GPIO_DATA_OFFSET+1)))  
  
#define MICO_GPIO_WRITE_DATA_BYTE2(X, Y) \  
    (__builtin_export((char)(Y),  
    (size_t)(X+GPIO_DATA_OFFSET+2)))  
  
#define MICO_GPIO_WRITE_DATA_BYTE3(X, Y) \  
    (__builtin_export((char)(Y),  
    (size_t)(X+GPIO_DATA_OFFSET+3)))  
  
/* Macros for accessing each byte of the Tristate Register */  
#define MICO_GPIO_READ_TRISTATE_BYTE0(X, Y) \  
    (Y) =  
    (__builtin_import((size_t)(X+GPIO_TRISTATE_OFFSET+0)))
```

Figure 19: Macros for Accessing Each Byte of the Data Register (Cont.)

```

#define MICO_GPIO_READ_TRISTATE_BYTE1(X, Y) \
    (Y) = \
    (__builtin_import((size_t)(X+GPIO_TRISTATE_OFFSET+1)))

#define MICO_GPIO_READ_TRISTATE_BYTE2(X, Y) \
    (Y) = \
    (__builtin_import((size_t)(X+GPIO_TRISTATE_OFFSET+2)))

#define MICO_GPIO_READ_TRISTATE_BYTE3(X, Y) \
    (Y) = \
    (__builtin_import((size_t)(X+GPIO_TRISTATE_OFFSET+3)))

/* Macros for writing each byte of the Tristate Register */
#define MICO_GPIO_WRITE_TRISTATE_BYTE0(X, Y) \
    (__builtin_export((char)(Y), \
    (size_t)(X+GPIO_TRISTATE_OFFSET+0)))

#define MICO_GPIO_WRITE_TRISTATE_BYTE1(X, Y) \
    (__builtin_export((char)(Y), \
    (size_t)(X+GPIO_TRISTATE_OFFSET+1)))

#define MICO_GPIO_WRITE_TRISTATE_BYTE2(X, Y) \
    (__builtin_export((char)(Y), \
    (size_t)(X+GPIO_TRISTATE_OFFSET+2)))

#define MICO_GPIO_WRITE_TRISTATE_BYTE3(X, Y) \
    (__builtin_export((char)(Y), \
    (size_t)(X+GPIO_TRISTATE_OFFSET+3)))

/* Macros for accessing each byte of the IRQ Mask Register */
#define MICO_GPIO_READ_IRQ_MASK_BYTE0(X, Y) \
    (Y) = \
    (__builtin_import((size_t)(X+GPIO_IRQ_MASK_OFFSET+0)))

#define MICO_GPIO_READ_IRQ_MASK_BYTE1(X, Y) \
    (Y) = \
    (__builtin_import((size_t)(X+GPIO_IRQ_MASK_OFFSET+1)))

#define MICO_GPIO_READ_IRQ_MASK_BYTE2(X, Y) \
    (Y) = \
    (__builtin_import((size_t)(X+GPIO_IRQ_MASK_OFFSET+2)))

#define MICO_GPIO_READ_IRQ_MASK_BYTE3(X, Y) \
    (Y) = \
    (__builtin_import((size_t)(X+GPIO_IRQ_MASK_OFFSET+3)))

/* Macros for writing each byte of the IRQ Mask Register */
#define MICO_GPIO_WRITE_IRQ_MASK_BYTE0(X, Y) \
    (__builtin_export((char)(Y), \
    (size_t)(X+GPIO_IRQ_MASK_OFFSET+0)))

#define MICO_GPIO_WRITE_IRQ_MASK_BYTE1(X, Y) \
    (__builtin_export((char)(Y), \
    (size_t)(X+GPIO_IRQ_MASK_OFFSET+1)))

```

Figure 19: Macros for Accessing Each Byte of the Data Register (Cont.)

```

#define MICO_GPIO_WRITE_IRQ_MASK_BYTE2(X, Y) \
    (__builtin_export((char)(Y), \
    (size_t)(X+GPIO_IRQ_MASK_OFFSET+2)))

#define MICO_GPIO_WRITE_IRQ_MASK_BYTE3(X, Y) \
    (__builtin_export((char)(Y), \
    (size_t)(X+GPIO_IRQ_MASK_OFFSET+3)))

/* Macros for accessing each byte of the Edge Capture
Register */
#define MICO_GPIO_READ_EDGE_CAPTURE_BYTE0(X, Y) \
    (Y) = \
    (__builtin_import((size_t)(X+GPIO_EDGE_CAPTURE_OFFSET+0)))

#define MICO_GPIO_READ_EDGE_CAPTURE_BYTE1(X, Y) \
    (Y) = \
    (__builtin_import((size_t)(X+GPIO_EDGE_CAPTURE_OFFSET+1)))

#define MICO_GPIO_READ_EDGE_CAPTURE_BYTE2(X, Y) \
    (Y) = \
    (__builtin_import((size_t)(X+GPIO_EDGE_CAPTURE_OFFSET+2)))

#define MICO_GPIO_READ_EDGE_CAPTURE_BYTE3(X, Y) \
    (Y) = \
    (__builtin_import((size_t)(X+GPIO_EDGE_CAPTURE_OFFSET+3)))

/* Macros for writing each byte of the Edge Capture Register
*/
#define MICO_GPIO_WRITE_EDGE_CAPTURE_BYTE0(X, Y) \
    (__builtin_export((char)(Y), \
    (size_t)(X+GPIO_EDGE_CAPTURE_OFFSET+0)))

#define MICO_GPIO_WRITE_EDGE_CAPTURE_BYTE1(X, Y) \
    (__builtin_export((char)(Y), \
    (size_t)(X+GPIO_EDGE_CAPTURE_OFFSET+1)))

#define MICO_GPIO_WRITE_EDGE_CAPTURE_BYTE2(X, Y) \
    (__builtin_export((char)(Y), \
    (size_t)(X+GPIO_EDGE_CAPTURE_OFFSET+2)))

#define MICO_GPIO_WRITE_EDGE_CAPTURE_BYTE3(X, Y) \
    (__builtin_export((char)(Y), \
    (size_t)(X+GPIO_EDGE_CAPTURE_OFFSET+3)))

```

Software Usage Examples

This section provides code example that demonstrate how to locate a GPIO device that is instantiated in the platform and how to directly access the data register using the macros provided in MicoGPIO.h header file.

Figure 20: Locating a GPIO and Accessing Its Data Register

```

include "DDStructs.h"
#include "MicoGPIO.h"

int main (void)
{
    /* Fetch GPIO instance named 'LED' */
    MicoGPIOCtx_t *leds = &gpio_LED;
    if (leds == 0) {
        /* failed to find a component named "LED" */
        return (-1);
    }

    /* Write 0x1 to programmable I/O pins via the data register */
    MICO_GPIO_WRITE_DATA_BYTE0 (leds->base, 0x1);

    /* Read back the value in the data register */
    unsigned char iValue;
    MICO_GPIO_READ_DATA_BYTE0 (leds->base, iValue);

    return 0;
}

```

Revision History

Component Version	Description
1.0	Initial release.
3.0 (7.0 SP2)	Cleaned up code. No function change.
3.1	Updated the Edge Capture Register clean method. Made IRQ Mask register readable.
3.2 (8.1 SP1)	WISHBONE data bus size is configurable to 8 or 32 bits. Register map is updated to accommodate 8/32-bit WISHBONE data bus.
3.3	Added LatticeMico8 software support.
3.4	Fixed issues with synthesis when component is configured for both input and output ports and the widths of each are different.
3.4	Updated document with new corporate logo.

Trademarks

Lattice Semiconductor Corporation, L Lattice Semiconductor Corporation (logo), L (stylized), L (design), Lattice (design), LSC, CleanClock, Custom Mobile Device, DiePlus, E2CMOS, Extreme Performance, FlashBAK, FlexiClock, flexiFLASH, flexiMAC, flexiPCS, FreedomChip, GAL, GDX, Generic Array Logic, HDL Explorer, iCE Dice, iCE40, iCE65, iCEcable, iCEchip, iCEcube, iCEcube2, iCEman, iCEprog, iCEsab, iCEsocket, IPexpress, ISP, ispATE, ispClock, ispDOWNLOAD, ispGAL, ispGDS, ispGDX, ispGDX2, ispGDXV, ispGENERATOR, ispJTAG, ispLEVER, ispLeverCORE, ispLSI, ispMACH, ispPAC, ispTRACY, ispTURBO, ispVIRTUAL MACHINE, ispVM, ispXP, ispXPGA, ispXPLD, Lattice Diamond, LatticeCORE, LatticeEC, LatticeECP, LatticeECP-DSP, LatticeECP2, LatticeECP2M, LatticeECP3, LatticeECP4, LatticeMico, LatticeMico8, LatticeMico32, LatticeSC, LatticeSCM, LatticeXP, LatticeXP2, MACH, MachXO, MachXO2, MACO, mobileFPGA, ORCA, PAC, PAC-Designer, PAL, Performance Analyst, Platform Manager, ProcessorPM, PURESPEED, Reveal, SiliconBlue, Silicon Forest, Speedlocked, Speed Locking, SuperBIG, SuperCOOL, SuperFAST, SuperWIDE, sysCLOCK, sysCONFIG, sysDSP, sysHSI, sysI/O, sysMEM, The Simple Machine for Complex Design, TraceID, TransFR, UltraMOS, and specific product designations are either registered trademarks or trademarks of Lattice Semiconductor Corporation or its subsidiaries in the United States and/or other countries. ISP, Bringing the Best Together, and More of the Best are service marks of Lattice Semiconductor Corporation.

Other product names used in this publication are for identification purposes only and may be trademarks of their respective companies.